



# nannidiesel

energy in blue

## QF 3.5

### 3,5kW



The engine illustrated above is not necessarily identical to the standard production engine. The specifications are subject to change without notice. The specifications are defined for marine pleasure use. For every other application, please consult us.



### General specifications

<b>a.c. output</b>	3,2 kW Cont 3,5 kW Max
<b>Power factor</b>	1
<b>Voltage</b>	V 230
<b>Frequency</b>	Hz 50
<b>Starting</b>	Electric
<b>Cooling eng / alt</b>	Sea water
<b>Fuel consumption</b>	1,74 l/h
<b>Noise level @ 7 mt</b>	52 dB(A)
<b>Noise level @ 3 mt</b>	56 dB(A)
<b>Noise level @ 1 mt</b>	60 dB(A)
<b>Dimension (with canopy)</b>	590x405x515mm
<b>Weight (with canopy)</b>	105 kg

### Alternator specifications

<b>Brand</b>	Nanni Diesel
<b>Model</b>	C35
<b>Type</b>	Synchronous
<b>Rotor and stator coat</b>	Epoxy
<b>Insulation class</b>	H
<b>High temperature winding protection</b>	Yes
<b>Tropicalization winding</b>	Yes
<b>Housing</b>	Aluminium
<b>Cooling</b>	Sea water
<b>Cooling system piping</b>	AISI 316
<b>Excitation</b>	Brushless
<b>Poles number</b>	2
<b>Distortions max</b>	6,5%
<b>Voltage variation</b>	+/- 5%
<b>Efficiency at 1/2 load</b>	82%
<b>Efficiency at 3/4 load</b>	83,5%
<b>Efficiency at 4/4 load</b>	83%

### Engine specifications

<b>Brand</b>	Farymann
<b>Model</b>	Diesel 18W
<b>Alimentation</b>	Diesel
<b>Power</b>	6.1 HP
<b>Speed / min</b>	3000 RPM
<b>Displacement</b>	0,290 litre
<b>Number of cylinders</b>	1
<b>Bore and stroke</b>	82 mm x 55 mm
<b>Compression ratio</b>	20 / 1
<b>Intake</b>	Atmospherical
<b>Cooling system</b>	Direct sea water
<b>Electrical equipment</b>	12 Volts
<b>Dry weight</b>	37 Kg
<b>Maximum installation angle</b>	15° (dynamic)



[www.nannidiesel.co.nz](http://www.nannidiesel.co.nz)

# QF 3.5

3.5 kW (3.8kW max)



- QF 3.5 -

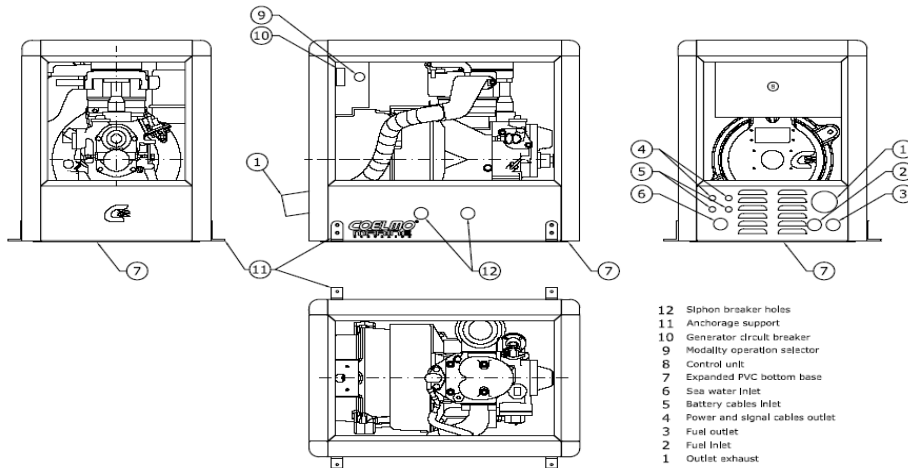

## Control panel (included)



The innovative control and command board EOS® represents the ideal interface for everyone that desires to have under control its Generating Set. The system is composed by one command and control panel mounted on bridge and by one control unit directly placed on the NANNIDIESEL Generating Set. The dimensions are:

- Control panel to be mounted on the bridge: 96x96mm fix-in household with hermetical retro-closing system;
- In and out signals circuit: mounted in the alternator terminal box; dimensions 190x135x40mm.

The data interchange between the two boards by means of a serial port using a simple signal cable type UTP CAT5 avoids further and bulky wirings from the engine housing to the control bridge. Furthermore it is possible to interface the control board with pre-existing centralized on board system (SCADA or similar). The display on the control board allows to visualize parameters and alarms.

## Alarms

- Low oil pressure
- High water temperature
- High exhaust temperature
- Alternator battery charger failure
- Fault start
- Mechanical failure
- High frequency generator
- Maintenance deadline
- Generator overload
- Low battery voltage
- Low alternator voltage
- Low alternator voltage
- Low frequency generator

## Parameters

- Amp
- Volt
- Hertz
- Vcc
- Time counter
- Maintenance remaining hours
- Water temperature (optional)
- Oil pressure (optional)

Each of these alarms will be visualized on the display and could be set to provide only signals, engine stop or start siren relay.