

T6.300 engine

224.4 kW (305 hp) at 3600 rpm

Toyota engine base

The design of the T6.300 is based on the 6 cylinder diesel engine which is used and tested on the Land Cruiser 4x4. The robustness of its engine block and its cast iron cylinder head as well as the efficiency of the different heat exchangers that compose the marinization developed by Nanni Diesel give you the assurance of quality, reliability and longevity that have already convinced many renowned boat builders.

Smooth and performing

The T6.300 boasts 6 in line cylinders, 4 valves per cylinder and 2 balancing shafts which result in unprecedented smoothness providing very quiet and virtually vibration-free comfort.

The T6.300 is perfectly suited for shaft line boats as a result of the combination of its

low rated speed of 3600 rpm, its 4.2 litres capacity and its high torque at low speed. The hole-shot of your boat is quicker and the obtained cruising speed at low rpm ensures low fuel consumption.

Compact and powerful

The power to weight ratio of this 305 horsepower engine is one of its greatest advantages. Its reduced dimensions ease installation and have already made it a preferred option on numerous boats.

With this engine you can count on the most dynamic motorization with plenty of power reserve for all situations.

Protecting the environment

The engine complies with the most stringent emission regulations in the world : EU-RCD, US-EPA and BSO.

Main characteristics

- Toyota base engine
- Big displacement
- High torque
- Turbo compressor & Intercooler
- Direct fuel injection
- 4 valves per cylinder
- 2 balance shafts

Available transmissions

- ZF63A (hydraulic) 8° angle
- ZF63 (hydraulic)
- ZF63IV (hydraulic) 12° angle
- ZF80A (hydraulic) 8° angle
- ZF220PL (hydraulic)
- TTM50A (hydraulic) 8° angle

Applications

- Semi-planning hulls
- Planning hulls

Technical specifications

Engine base	Toyota
Rated power (kW/hp)*	224.4 / 305
Rated rpm (rpm)*	3600
Displacement (cm ³ /in ³)	4163 / 254
Number of cylinders	6 in line
Bore and stroke (mm/in)	94 x 100 / 3.7 x 3.93
Compression ratio	15.7:1
Combustion system	Direct
Intake	Turbo compressor & Intercooler
Cooling	Closed cooling with heat exchanger
El. equipment / Alternator	12V / 80A
Instrument panel	C4-T
Transmission	Hydraulic gearbox
Engine Max Install. Angle	7° (dynamic)
Certifications	EPA, BSO, EU-RCD
Dry weight with TTM40A (kg/lb)	469 / 1034
Connections diameter	
Exhaust (mm/in)	104 / 4.09
Fuel (mm/in)	10 / 0.39
Sea Water (mm/in)	38 / 1.49

* At engine flywheel, according to ISO 8665-1

T6.300 engine

224.4 kW (305 hp)

Standard equipment

- Warranty certificate
- Exhaust manifold With water injection
- Exhaust elbow
- Closed cooling with heat exchanger
- Compressed air cooler
- 6 meters electrical harness
- Fuel filter with audio alarm (Water)
- Sea water filter on the engine
- Hydraulic transmission (8°)
- Owner's Manual
- Coolant circulating pump
- Rotary injection pump
- Oil extraction pump
- Sea water pump
- Prearrangement for control cables
- Integrated oil cooler
- Electrical stop
- Engine flexible mounts
- Electrical system 12 V
- Thermostat

Optional equipment

- Separated instruments
- Electrical harness
- Flying bridge instrument panel
- V drive transmission
- Alternator 120A
- Remote control
- Exhaust system
- Sea water hoses
- Fuel hoses
- Sea water filter
- Flexible coupling

C4-T panel

- Ignition key / Start button
- Tachometer and hour meter / Voltmeter
- Battery charge warning light
- Engine control warning light
- Turbo warning light
- Preheating warning light
- Water in fuel filter warning light
- Oil pressure indicator
- Oil pressure warning light
- Coolant temperature indicator
- Preheating warning light

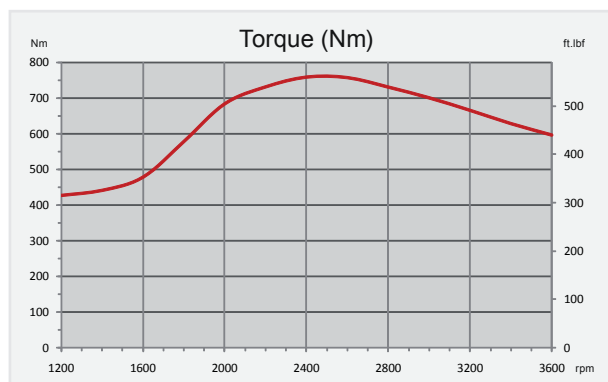
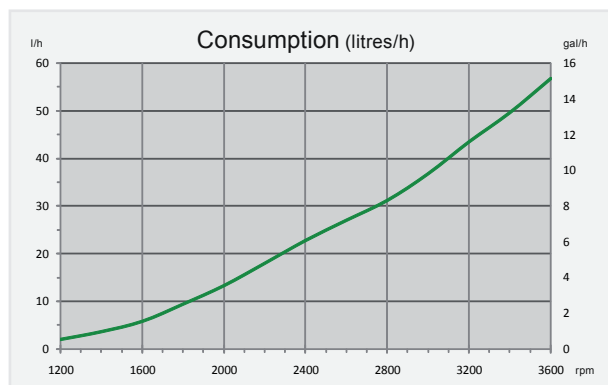
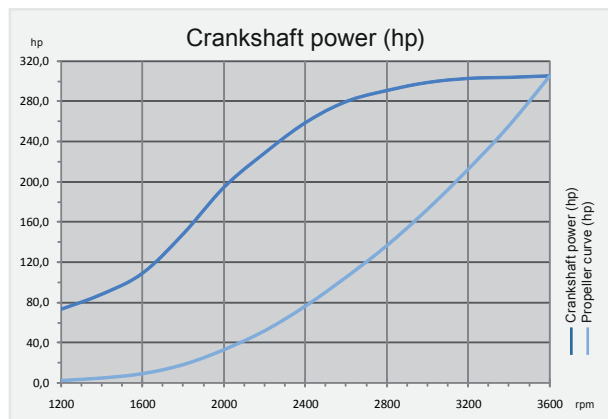
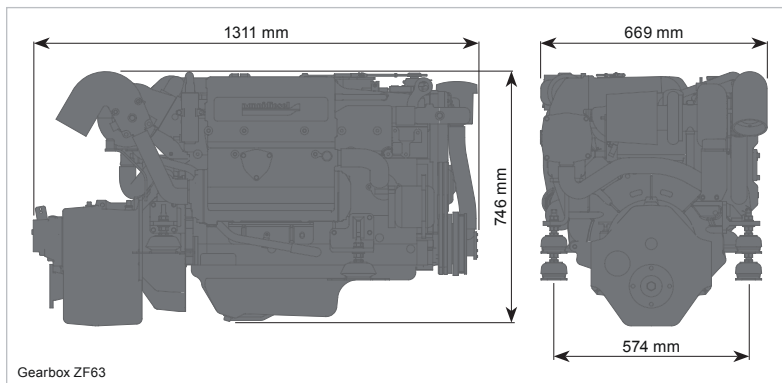
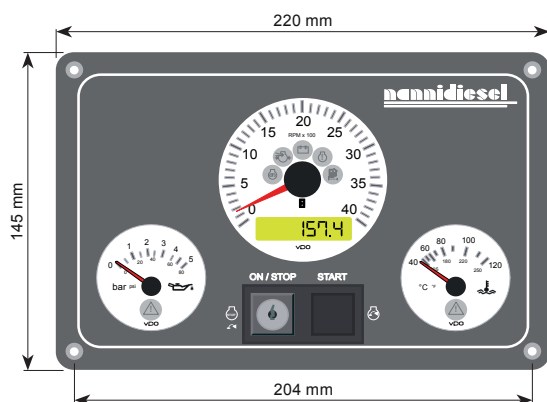

Nanni Industries S.A.S. France

11, Avenue Mariotte-Zone Industrielle

BP 107- 33260 La Teste France

Tel : + 33 (0)5 56 22 30 60

Fax : +33 (0)5 56 22 30 79

www.nannidiesel.com

Certified ISO by



Your dealer